

T5 eco-line opbouwarmatuur

230V 50/60Hz

- v.v. geïntegreerd voorschakelapparaat.
- Horizontale klipbevestiging (standaard)
- Geïntegreerd ministecker systeem
- Veiligheidsklasse II
- v.v. kunststof afdekking
- v.v. lamp T5
- Opbouw maat (B x H): 23 x 42 mm.
- Aansluit- en koppelsnoeren separaat leverbaar.

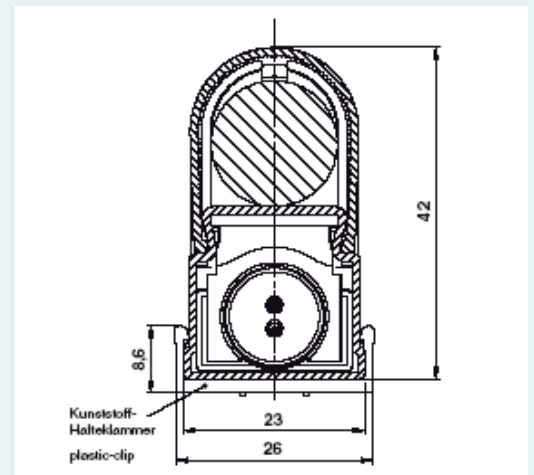
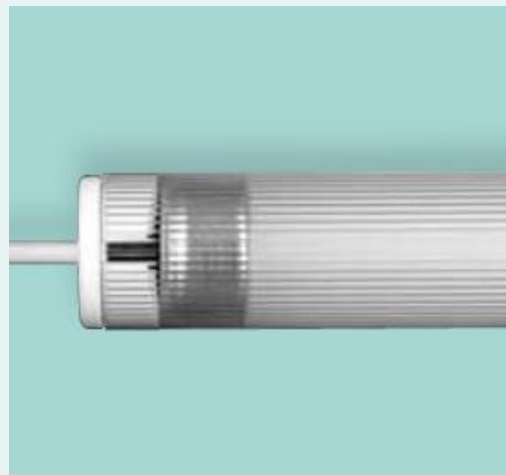

Bevestigingsclip
horizontaal montage



Bevestigingsclip
verticaal montage

Direct-connector

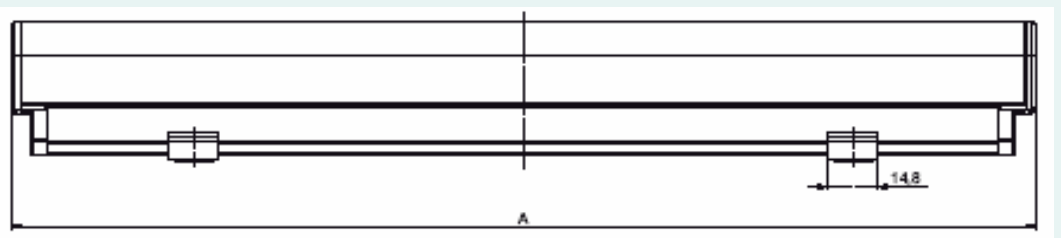
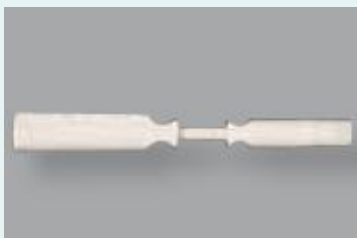

| Art. nummer | Wattage | Lengte | Lamp | Lichtkleur | Art. nummer | Lichtkleur | Gewicht |
|-------------|---------|---------|------|------------|-------------|------------|---------|
| EL52948601 | 6W | 235 mm | T5 | cw840 | EL52952801 | ww830 | 121 g |
| EL52904201 | 8W | 311 mm | T5 | cw840 | EL52918901 | ww830 | 150 g |
| EL52904301 | 13W | 540 mm | T5 | cw840 | EL52919001 | ww830 | 223 g |
| EL52928301 | 14W | 572 mm | T5 | cw840 | EL52948801 | ww830 | 241 g |
| EL52904401 | 21W | 872 mm | T5 | cw840 | EL52919101 | ww830 | 335 g |
| EL52904501 | 28W | 1172 mm | T5 | cw840 | EL52946001 | ww830 | 417 g |
| EL52946101 | 35W | 1472 mm | T5 | cw840 | EL52946201 | ww830 | 581 g |